



THE FLEXIBLE HEAVY-DUTY ROBOTS

The Z-Series heavy-duty robots were developed using Kawasaki's advanced technology and extensive experience in automation. The robust low-maintenance designs are directly responsible for improved production line efficiencies in automotive and general industry applications.

ZXE165U

| | |
|-----------------------------|------------|
| Payload | 165 kg |
| Horizontal Reach | 2,651 mm |
| Vertical Reach | 3,415 mm |
| Repeatability | ±0.3 mm |
| Maximum Linear Speed | 2,500 mm/s |

Applications

- Assembly
- Dispensing
- Friction Spot Joining
- Machine Tending
- Material Handling
- Material Removal
- Spot Welding

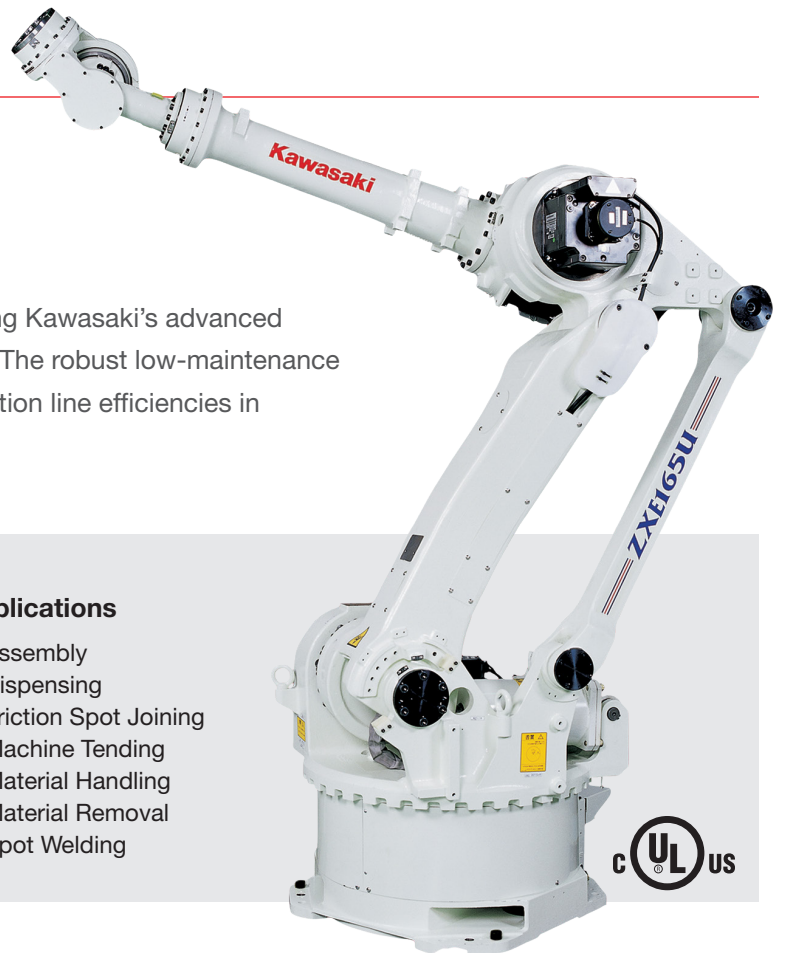

HIGH QUALITY & LOW-MAINTENANCE

The Z-Series Robots boast industry leading MTBF and 10,000 hour maintenance intervals, which translate to low operating costs and the highest production efficiencies.

CYCLE TIME ADVANTAGE

The Z Robots along with the ultra high processing speed capabilities of the Kawasaki E Controller can achieve superior operating speeds. Add the high-speed option package and cycle times can be reduced by up to 20% as compared to previous models. Faster speeds translate to shorter cycle times, resulting in maximum production.

WIDE WORK ENVELOPE

The Kawasaki Z Robot combines a long reach arm with a minimal amount of dead space for the widest work envelope in its class. In addition, the patented Kawasaki Hybrid Link Configuration enables the arm to rotate back over itself without having to rotate the base joint, thereby improving efficiency and minimizing power consumption.

SPACE SAVING DESIGN WITH INTEGRATED FEATURES

The small footprint of these high payload long reach robots allows for installations in confined areas. The Z-Series Robots are available with integrated pneumatic piping, wiring, and fork lift pockets, limiting the amount of work space required and minimizing potential interference.

PROTECTION FROM HARSH ENVIRONMENTS

Z-Series Robots can operate in some of the harshest environments due to the Kawasaki sealed arm design. The wrist portion of the robot has an Ingress Protection classification of IP67, while the other areas of the arm are rated at IP65. Robot maintenance due to contamination can be eliminated.

ARM ID MEMORY

Kawasaki's Arm ID board enables the robot arm to be interchanged with any E Controller. The ID board stores all of the necessary servo encoder data. In the event of a production emergency, the controller can quickly and easily be replaced to allow for any service and maintenance procedures to be performed. This feature greatly limits potential system downtime.

UPGRADEABLE

The Z-Series robot line is manufactured using modular components and a common software platform. This flexible design allows some models to be modified to alter reach, payload capacities and speed. Both hardware and software alterations can easily be performed in the field. The ability to change the robot characteristics provide for greater flexibility to accommodate production and system changes.

MOTION RANGE & DIMENSIONS

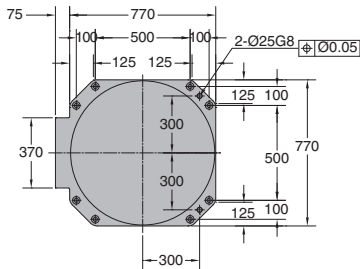
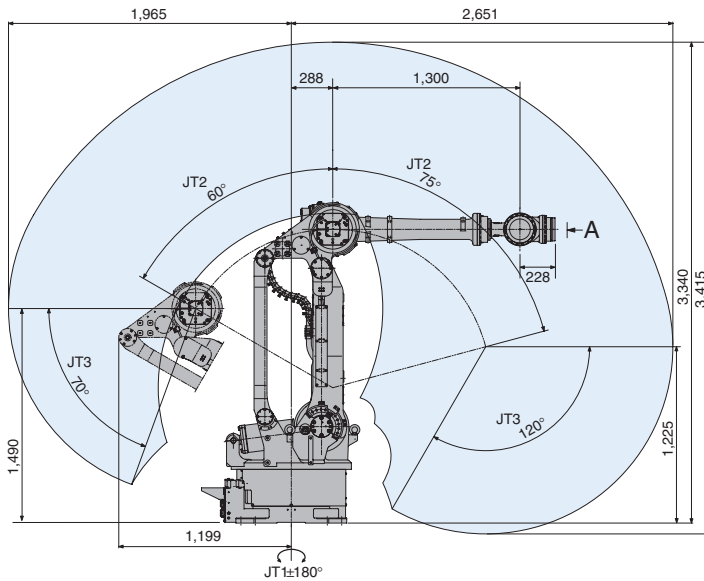

INSTALLATION DIMENSIONS

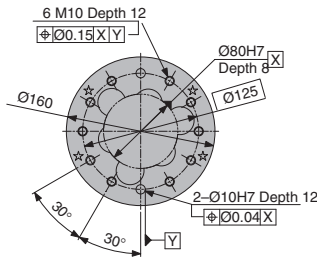

VIEW A

(mm)

Note: Detailed drawings are available upon request.

ZXE165U SPECIFICATIONS

| | | | |
|--|--|---------------------------------------|-------------------------|
| Type | Articulated | | |
| Degrees of Freedom | 6 axes | | |
| Payload | 165 kg | | |
| Horizontal Reach | 2,651 mm | | |
| Vertical Reach | 3,415 mm | | |
| Repeatability | ±0.3 mm | | |
| Maximum Linear Speed | 2,500 mm/s at robot flange | | |
| Work Envelope (degrees) & Maximum Speed (degrees/s) | Axis | Motion Range | Maximum Speed |
| | JT1 | ±180° | 110°/s |
| | JT2 | +75° ~ -60° | 110°/s |
| | JT3 | +250° ~ -120° | 115°/s |
| | JT4 | ±360° | 140°/s |
| | JT5 | ±130° | 155°/s |
| Wrist Load Capacity | Axis | Maximum Torque | Moment of Inertia |
| | JT4 | 911.4 N·m | 165.5 kg·m ² |
| | JT5 | 911.4 N·m | 165.5 kg·m ² |
| Wrist Load Capacity | JT6 | 451.0 N·m | 46.9 kg·m ² |
| | Motor(s) | Brushless AC Servomotor | |
| Brakes | All axes | | |
| Hard Stop(s) | Adjustable mechanical stopper JT1 | | |
| Limit Switch | End of stroke limit switch JT1 | | |
| Mass | 1,350 kg (excluding Options) | | |
| Body Color | Kawasaki Standard | | |
| Installation | Floor (includes fork pockets) | | |
| Environmental Conditions | Temperature | 0 ~ 45° C | |
| | Humidity | 35 ~ 85 % (no dew, nor frost allowed) | |
| | Vibration | Less than 0.5 G | |
| Protection Classification | Wrist: IP67 | Base: IP65 | * Equivalent |
| Built-in Utilities | Pneumatic piping (ø12 x 2 lines) | | |
| Options | Linear track options | | |
| | Base plate | | |
| | Adjustable mechanical stopper JT2/JT3 | | |
| | Limit switch JT2/JT3 | | |
| | Signal harness (up to 24 inputs and 8 outputs) | | |
| | Double/single solenoid valves (2 units max.) | | |
| | Internal wiring (37 wires inside robot arm) | | |
| Air cleaning equipment (filter, regulator, mist separator) | | | |
| Piping for cooling water | | | |
| Wrist flange adapter with ø92 mm mounting pattern | | | |
| Controller | E32 (See E Controller data sheet for specifications) | | |